

Symbols and designations

Symbols and designations, based on the IEC 617-series, IEC 617-7 (1983) and others

Block symbols and qualifying symbols

1. General block symbols

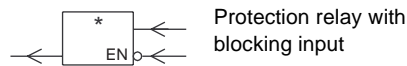
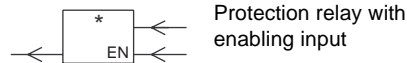
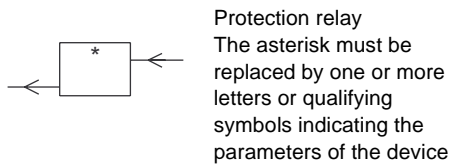

2. Parameters and functions

I	Current
$I \leftarrow$	Reverse current
I_d	Differential current
I_d/I	Percentage differential current (current restraint)
I_{nf}	Current of n^{th} harmonic
$I_1, (I_p)$	Positive sequence current component
$I_2, (I_n)$	Negative sequence current component
$I_0, (I_h)$	Zero sequence current component
I_{rsd}	Residual current

$I \perp$	Earth fault current
$I \downarrow$	Current to frame
I_N	Current in the neutral conductor
I_{N-N}	Current between neutrals of two polyphase systems
I_{ub}	Current unbalance
U	Voltage
dP/dt	Power derivative
Q	Reactive power
R	Resistance
X	Reactance
Z	Impedance
f	Frequency
n	Rotational speed
F	Magnetic flux
j	Phase angle
Q	Temperature
	Thermal effect
	Flash-over, Fault
	Delay
	Delay at transition to ON-state, pick-up delay

Symbols and designations (cont'd)

SYNC	Synchronizing (check)
BLOCK	Blocking device
LO	Lock-out
TCS	Trip circuit supervision

X/Y	Translation of signal
A/D or $\Pi/\#$	Analog to digital conversion
>	Operation above a set value, e.g. overcurrent
<	Operation below a set value, e.g. underimpedance
>>	Operation above a high set stage

Examples of protection relays

Relays and relay parts

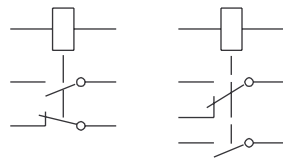

Auxiliary relay with mechanical contacts

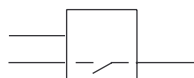

Auxiliary relay, block symbol

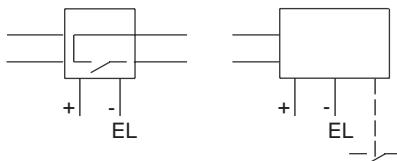

Static relay with terminals for external auxiliary voltage supply

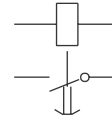

Relay with make contact, delayed when the relay is energized. Pick-up delay

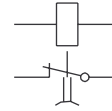

Relay with brake contact, delayed when the relay is deenergized. Drop-out delay

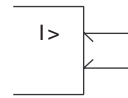

Overcurrent relay with short-circuiting connector

Coils



Relay with one winding



Relay with two windings



Operate and reset coil

Relay contacts

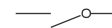

Make contact



Brake contact

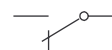

Change-over contact (break before make)



Change-over contact, delayed when releasing

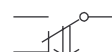

Change-over contact, delayed when operating

Switch contacts

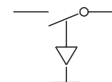

Push-button operated contact with automatic return

Test switch contacts

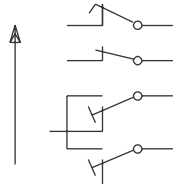

1. Break-contact (voltage supply circuit), late opening and early closing upon insertion and withdrawal, respectively, of the test handle. Note that the test switch contacts number 1 and 18 (12) will not be opened when the test handle RTXH 18 (24) is inserted.
2. Break-contact (trip circuits), early opening and late closing upon insertion and withdrawal respectively, of the test handle.
3. Make before break contacts with shorting connection (CT secondary circuits), late opening and early closing upon insertion and withdrawal respectively, of the test handle.

Indications



Indicator with self reset, indicates when coil is energized. Annunciator element (target)



Indicator light, lamp or led



Hand reset indication, indicates when the coil is energized and remains visible even when the coil is not energized

Components



Capacitor, general symbol



Polarized capacitor



Resistor, general symbol

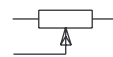

Potentiometer
Resistor with two fixed end terminals and one movable terminal

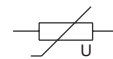

Varistor
Voltage dependent non-linear resistor

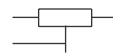

Fixed trimming resistor
Resistor with two fixed end terminals and one movable terminal for fixed setting (trimming)



Diode, semiconductor





Reference diode
Zener diode
Voltage regulator diode









Single-phase transformer with two windings

Symbols and designations (cont'd)



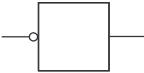

Designations

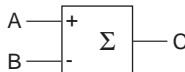
I_r, U_r	Rated current, voltage
I_b, U_b	Base current, voltage
I_s, U_s	Set current, voltage
L1, L2, L3, N	Phase designations
	Alternating current, ac
	Direct current, dc
	Ac and dc
UL	Auxiliary tripping voltage
EL	Auxiliary electronic voltage
RL	Auxiliary relay voltage

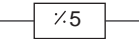
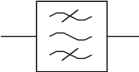
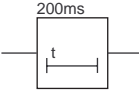
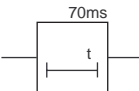
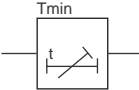
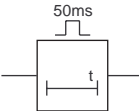
Logic elements

	Logic setting signal (including on-off)
	Binary input signal
	AND gate $C = A \times B$
	OR gate $C = A + B$
	Input inverted
	Output inverted
	Signal summation circuit $C = A + (-B)$

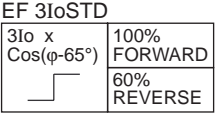
	Divider (by 5)
	Band-pass filter
	Time element delayed on pick-up, 200 ms
	Time element delayed on drop-out, 70 ms
	Adjustable time element delayed on pick-up
	Time element non re-triggable pulse

	Loop delay output (T) = input (T-1)
	Light emitting diode (LED)
	Earth fault over-current dependent time function
	Directional earth fault overcurrent function
	Level detector, earth fault voltage check

IEEE device numbers and functions

IEEE device numbers and functions for switchgear apparatus

The devices in switching equipments are referred to by numbers, with appropriate suffix letters when necessary, according to the functions they perform.

These numbers are based on a system adopted as standard for automatic switchgear by IEEE, and incorporated in American Standard C37.2-1979. This system is used in connection diagrams, in instruction books, and in specifications.

Device number	Definition and function
---------------	-------------------------

- | | |
|---|--|
| 1 | Master element is the initiating device, such as a control switch, voltage relay, float switch etc., that serves either directly, or through such permissive devices as protective and time-delay relays, to place an equipment in or out of operation. |
| 2 | Time-delay starting or closing relay is a device that functions to give a desired amount of time delay before or after any point of operation in a switching sequence or protective relay system, except as specifically provided by device functions 48, 62 and 79 described later. |
| 3 | Checking or interlocking relay is a device that operates in response to the position of a number of other devices, (or to a number of predetermined conditions), in an equipment to allow an operating sequence to proceed, to stop, or to provide a check of the position of these devices or of these conditions for any purpose. |
| 4 | Master contactor is a device, generally controlled by device No. 1 or equivalent, and the required permissive and protective devices, that serve to make and break the necessary control circuits to place an equipment into operation under the desired conditions and to take it out of operation under other or abnormal conditions. |
| 5 | Stopping device is a control device used primarily to shut down an equipment and hold it out of operation. [This device may be manually or electrically actuated, but excludes the function of electrical lockout (see device function 86) on abnormal conditions.] |

- | Device number | Definition and function |
|---------------|--|
| 6 | Starting circuit breaker is a device whose principal function is to connect a machine to its source of starting voltage. |
| 7 | Rate-of-rise relay is a relay that functions on an excessive rate of rise of current. |
| 8 | Control power disconnecting device is a disconnecting device, such as a knife switch, circuit breaker, or pull-out fuse block, used for the purpose of respectively connecting and disconnecting the source of control power to and from the control bus or equipment. |
| 9 | Reversing device is used for the purpose of reversing a machine field or for performing any other reversing functions. |
| 10 | Unit sequence switch is used to change the sequence in which units may be placed in and out of service in multiple-unit equipment. |
| 11 | Multifunction device is a device that performs three or more comparatively important functions that could only be designated by combining several of these device function numbers. All of the functions performed by device 11 shall be defined in the drawing legend or device function list. |
| 12 | Overspeed device is usually a direct-connected speed switch that functions on machine overspeed. |
| 13 | Synchronous-speed device , such as a centrifugal speed switch, a slip frequency relay, a voltage relay, an undercurrent relay, or any other type of device that operates at approximately the synchronous speed of a machine. |
| 14 | Underspeed device functions when the speed of a machine falls below a pre-determined value. |

IEEE device numbers
and functions (cont'd)

Device number	Definition and function	Device number	Definition and function
15	Speed or frequency matching device functions to match and hold the speed or the frequency of a machine or of a system equal to, or approximately equal to, that of another machine, source, or system.	23	Temperature control device functions to raise or to lower the temperature of a machine or other apparatus, or of any medium, when its temperature falls below or rises above a pre-determined value. Note: An example is a thermostat that switches on a space heater in a switchgear assembly when the temperature falls to a desired value as distinguished from a device that is used to provide automatic temperature regulation between close limits and would be designated as 90T.
16	Reserved for future application	24	Volts per hertz relay is a relay that functions when the ratio of voltage to frequency exceeds a preset value. The relay may have an instantaneous or a time characteristic.
17	Shunting or discharge switch serves to open or to close a shunting circuit around any piece of apparatus (except a resistor), such as a machine field, a machine armature, a capacitor, or a reactor. Note: This excludes devices that perform such shunting operations as may be necessary in the process of starting a machine by devices 6 or 42, or their equivalent, and also excludes device 73 function that serves for the switching of resistors.	25	Synchronizing or synchronism-check device operates when two ac circuits are within the desired limits of frequency, phase angle, or voltage to permit or to cause the paralleling of these two circuits.
18	Accelerating or decelerating device is used to close or to cause the closing of circuits that are used to increase or decrease the speed of a machine.	26	Apparatus thermal device functions when the temperature of the protected apparatus (other than the load-carrying windings of machines and transformers as covered by device function number 49) or of a liquid or other medium exceeds a predetermined value; or when the temperature of the protected apparatus or of any medium decreases below a predetermined value.
19	Starting-to-running transition contactor is a device that operates to initiate or cause the automatic transfer of a machine from the starting to the running power connection.	27	Undervoltage relay is a relay that operates when its input voltage is less than a predetermined value.
20	Electrically operated valve is an electrically operated, controlled, or monitored valve used in a fluid, air, gas, or vacuum line. Note: The function of the valve may be indicated by the use of the suffixes, see page 11.	28	Flame detector is a device that monitors the presence of the pilot or main flame in such apparatus as a gas turbine or a steam boiler.
21	Distance relay is a relay that functions when the circuit admittance, impedance, or reactance increases or decreases beyond a predetermined value.	29	Isolating contactor is used expressly for disconnecting one circuit from another for the purposes of emergency operation, maintenance, or test.
22	Equalizer circuit breaker is a breaker that serves to control or to make and break the equalizer or the current balancing connections for a machine field, or for regulating equipment, in a multiple unit installation.		

Device number	Definition and function	Device number	Definition and function
30	Annunciator relay is a nonautomatically reset device that gives a number of separate visual indications upon the functioning of protective devices and that may also be arranged to perform a lock-out function.	38	Bearing protective device functions on excessive bearing temperature or on other abnormal mechanical conditions associated with the bearing, such as undue wear, which may eventually result in excessive bearing temperature or failure.
31	Separate excitation device connects a circuit, such as the shunt field of a synchronous converter, to a source of separate excitation during the starting sequence; or one which energizes the excitation and ignition circuits of a power rectifier.	39	Mechanical condition monitor is a device that functions upon the occurrence of an abnormal mechanical condition (except that associated with bearings as covered under device function 38), such as excessive vibration, eccentricity, expansion, shock, tilting, or seal failure.
32	Directional power relay is a relay that operates on a predetermined value of power flow in a given direction or upon reverse power flow such as that resulting from the motoring of a generator upon loss of its prime mover.	40	Field relay functions on a given or abnormally low value or failure of machine field current, or on an excessive value of the reactive component of armature current in an ac machine indicating abnormally low field excitation.
33	Position switch makes or breaks contact when the main device or piece of apparatus that has no device function number reaches a given position.	41	Field circuit breaker is a device that functions to apply or remove the field excitation of a machine.
34	Master sequence device is a device such as a motor operated multicontact switch, or the equivalent, or a programming device, such as a computer, that establishes or determines the operating sequence of the major devices in an equipment during starting and stopping or during other sequential switching operations.	42	Running circuit breaker is a device whose principal function is to connect a machine to its source of running or operating voltage. This function may also be used for a device, such as a contactor, that is used in series with a circuit breaker or other fault protecting means, primarily for frequent opening and closing of the circuit.
35	Brush-operating or slip-ring short-circuiting device is used for raising, lowering or shifting the brushes of a machine; short-circuiting its slip rings; or engaging or disengaging the contacts of a mechanical rectifier.	43	Manual transfer or selector device is a manually operated device that transfers the control circuits in order to modify the plan of operation of the switching equipment or of some of the devices.
36	Polarity or polarizing voltage device operates, or permits the operation of, another device on a predetermined polarity only or that verifies the presence of a polarizing voltage in an equipment.	44	Unit sequence starting relay is a relay that functions to start the next available unit in multiple unit equipment upon the failure or nonavailability of the normally preceding unit.
37	Undercurrent or underpower relay functions when the current or power flow decreases below a predetermined value.	45	Atmospheric condition monitor is a device that functions upon the occurrence of an abnormal atmospheric condition, such as damaging fumes, explosive mixtures, smoke, or fire.

IEEE device numbers
and functions (cont'd)

Device number	Definition and function	Device number	Definition and function
46	Reverse-phase or phase-balance current relay is a relay that functions when the polyphase currents are of reverse phase sequence or when the polyphase currents are unbalanced or contain negative phase-sequence components above a given amount.	53	Exciter or dc generator relay is a relay that forces the dc machine field excitation to build up during starting or that functions when the machine voltage has built up to a given value.
47	Phase-sequence or phase-balance voltage relay functions upon a pre-determined value of polyphase voltage in the desired phase sequence, or when the polyphase voltages are unbalanced, or when the negative phase-sequence voltage exceeds a given amount.	54	Turning gear engaging device is an electrically operated, controlled, or monitored device that functions to cause the turning gear to engage (or disengage) the machine shaft.
48	Incomplete sequence relay is a relay that generally returns the equipment to the normal, or off, position and locks it out if the normal starting, operating, or stopping sequence is not properly completed within a pre-determined time. If the device is used for alarm purposes only, it should preferably be designated as 48A (alarm).	55	Power factor relay is a relay that operates when the power factor in an ac circuit rises above or falls below a predetermined value.
49	Machine or transformer thermal relay is a relay that functions when the temperature of a machine armature winding or other load-carrying winding or element of a machine or power transformer exceeds a predetermined value.	56	Field application relay is a relay that automatically controls the application of the field excitation to an ac motor at some predetermined point in the slip cycle.
50	Instantaneous overcurrent relay is a relay that functions instantaneously on an excessive value of current.	57	Short-circuiting or grounding device is a primary circuit switching device that functions to short circuit or ground a circuit in response to automatic or manual means.
51	Ac time overcurrent relay is a relay with either a definite or inverse time characteristic that functions when the ac input current exceeds a predetermined value, and in which the input current and operating time are independently related or inversely related through a substantial portion of the performance range.	58	Rectification failure relay is a device that functions if a power rectifier fails to conduct or block properly.
52	Ac circuit breaker is a device that is used to close and interrupt an ac power circuit under normal conditions or to interrupt this circuit under fault or emergency conditions.	59	Overvoltage relay is a relay that operates when its input voltage is higher than a predetermined value.
		60	Voltage or current balance relay is a relay that operates on a given difference in voltage, or current input or output, of two circuits.
		61	Density switch or sensor is a device that operates on a given value, or a given rate of change, of gas density.
		62	Time-delay stopping or opening relay is a time-delay relay that serves in conjunction with the device that initiates the shutdown, stopping, or opening operation in an automatic sequence or protective relay system.
		63	Pressure switch is a switch that operates on given values, or on a given rate of change, of pressure.

Device number	Definition and function	Device number	Definition and function
64	<p>Ground detector relay is a relay that operates upon failure of machine or other apparatus insulation to ground, or on flashover of a dc machine to ground.</p> <p>Note: This function is assigned only to a relay which detects the flow of current from the frame of a machine or enclosing case or structure of a piece of apparatus to ground, or detects a ground on a normally ungrounded winding or circuit. It is not applied to a device connected in the secondary neutral of a current transformer, or in the secondary neutral of current transformers, connected in the power circuit of a normally grounded system.</p>	69	<p>Permissive control device is generally, a two-position device that in one position permits the closing of a circuit breaker, or the placing of an equipment into operation, and in the other position prevents the circuit breaker or the equipment from being operated.</p>
65	<p>Governor is the assembly of fluid, electrical, or mechanical control equipment used for regulating the flow of water, steam, or other media to the prime mover for such purposes as starting, holding speed or load, or stopping.</p>	70	<p>Rheostat is a variable resistance device used in an electric circuit which is electrically operated or has other electrical accessories, such as auxiliary, position, or limit switches.</p>
66	<p>Notching or jogging device functions to allow only a specified number of operations of a given device or equipment, or a specified number of successive operations within a given time of each other. It is also a device that functions to energize a circuit periodically or for fractions of specified time intervals, or that is used to permit intermittent acceleration or jogging of a machine at low speeds for mechanical positioning.</p>	71	<p>Level switch is a switch that operates on given values, or on a given rate of change, of level.</p>
67	<p>Ac directional overcurrent relay is a relay that functions on a desired value of ac overcurrent flowing in a predetermined direction.</p>	72	<p>Dc circuit breaker is used to close and interrupt a dc power circuit under normal conditions or to interrupt this circuit under fault or emergency conditions.</p>
68	<p>Blocking relay is a relay that initiates a pilot signal for blocking of tripping on external faults in a transmission line or in other apparatus under predetermined conditions, or that cooperates with other devices to block tripping or to block reclosing on an out-of-step condition or on power swings.</p>	73	<p>Load-resistor contactor is used to shunt or insert a step of load limiting, shifting, or indicating resistance in a power circuit, or to switch a space heater in circuit, or to switch a light, or regenerative load resistor of a power rectifier or other machine in and out of circuit.</p>
		74	<p>Alarm relay is a relay other than an annunciator, as covered under device function 30, that is used to operate, or that operates in connection with, a visual or audible alarm.</p>
		75	<p>Position changing mechanism is a mechanism that is used for moving a main device from one position to another in an equipment; for example, shifting a removable circuit breaker unit to and from the connected, disconnected, and test positions.</p>
		76	<p>Dc overcurrent relay is a relay that functions when the current in a dc circuit exceeds a given value.</p>

IEEE device numbers and functions (cont'd)

Device number	Definition and function	Device number	Definition and function
77	Telemetering device is a transmitter used to generate and transmit to a remote location an electrical signal representing a measured quantity, or a receiver used to receive the electrical signal from a remote transmitter and convert the signal to represent the original measured quantity.	86	Lockout relay is an electrically operated hand or electrically reset auxiliary relay that is operated upon the occurrence of abnormal conditions to maintain associated equipment or devices out of service until it is reset.
78	Phase-angle measuring or out-of-step protective relay is a relay that functions at a predetermined phase angle between two voltages, or between two currents, or between voltage and current.	87	Differential protective relay is a protective relay that functions on a percentage, or phase angle, or other quantitative difference between two currents or some other electrical quantities.
79	Ac reclosing relay is a relay that controls the automatic reclosing and locking out of an ac circuit interrupter.	88	Auxiliary motor or motor generator is a device used for operating auxiliary equipment, such as pumps, blowers, exciters, rotating magnetic amplifiers, etc.
80	Flow switch is a switch that operates on given values, or on a given rate of change, of flow.	89	Line switch is used as a disconnecting, load interrupter, or isolating switch in an ac or dc power circuit. (This device function number is normally not necessary unless the switch is electrically operated or has electrical accessories, such as an auxiliary switch, a magnetic lock, etc.)
81	Frequency relay is a relay that responds to the frequency of an electrical quantity, operating when the frequency or rate of change of frequency exceeds or is less than a predetermined value.	90	Regulating device functions to regulate a quantity or quantities, such as voltage, current, power, speed, frequency, temperature, and load, at a certain value or between certain (generally close) limits for machines, tie lines, or other apparatus.
82	Dc load-measuring reclosing relay is a relay that controls the automatic closing and reclosing of a dc circuit interrupter, generally in response to load circuit conditions.	91	Voltage directional relay is a relay that operates when the voltage across an open circuit breaker or contactor exceeds a given value in a given direction.
83	Automatic selective control or transfer relay is a relay that operates to select automatically between certain sources or conditions in an equipment or that performs a transfer operation automatically.	92	Voltage and power directional relay is a relay that permits or causes the connection of two circuits when the voltage difference between them exceeds a given value in a predetermined direction and causes these two circuits to be disconnected from each other when the power flowing between them exceeds a given value in the opposite direction.
84	Operating mechanism is the complete electrical mechanism or servo-mechanism, including the operating motor, solenoids, position switches, etc., for a tap changer, induction regulator, or any similar piece of apparatus that otherwise has no device function number.	93	Field-changing contactor functions to increase or decrease, in one step, the value of field excitation on a machine.
85	Carrier or pilot-wire receiver relay is a relay that is operated or restrained by a signal used in connection with carrier-current or dc pilot-wire fault directional relaying.		

Device number	Definition and function
94	Tripping or trip-free relay functions to trip a circuit breaker, contactor, or equipment, or to permit immediate tripping by other devices; or to prevent immediate reclosing of a circuit interrupter if it should open automatically, even though its closing circuit is maintained closed.
95	Used only for specific applications on individual installations where none of the assigned numbered functions from 1 to 94 is suitable.
96	
97	
98	
99	

Supervisory control and indication.

A similar series of numbers, prefixed by the letters RE (for "remote") shall be used for the interposing relays performing functions that are controlled directly from the supervisory system. Typical examples of such device functions are: RE1, RE5 and RE94.

Note: The user of the "RE" prefix for this purpose in place of the former 200 series of numbers now makes it possible to obtain increased flexibility of the device function numbering system. For example, in pipeline pump stations, the numbers 1 through 99 are applied to device functions that are associated with the over-all station operation. A similar series of numbers, starting with 101 instead of 1, are used for those device functions that are associated with unit 1; a similar series starting with 201 for device functions that are associated with unit 2; and so on, for each unit in these installations.

Devices performing more than one function

If one device performs two relatively important functions in an equipment so that it is desirable to identify both of these functions, this may be done by using a double function number and name such as:

50/51 Instantaneous and Time Overcurrent relay.

Suffix numbers

If two or more devices with the same function number and suffix letter (if used) are present in the same equipment, they may be distinguished by numbered suffixes as for example, 52X-1, 52X-2 and 52X-3, when necessary.

Suffix letters

Suffix letters are used with device function numbers for various purposes. In order to prevent possible conflict each suffix letter should have only one meaning in an individual equipment. All other words should use the abbreviations as contained in American Standard Z32.13-1950, or latest revision thereof, or should use some other distinctive abbreviation, or be written out in full each time they are used. The meaning of each single suffix letter, or combination of letters, should be clearly designated in the legend on the drawings or publications applying to the equipment. In cases where the same suffix (consisting of one letter or a combination of letters) has different meanings in the same equipment, depending upon the device function number with which is used, then the complete device function number with which it is used, the complete device function number with its suffix letter or letters and its corresponding function name should be listed in the legend in each case, as follows: 90V, Voltage regulator.

Lower case (small) suffix letters are used in practically all instances on electrical diagrams for the auxiliary, position, and limit switches. Capital letters are generally used for all other suffix letters.

The letters should generally form part of the device function designation, are usually written directly after the device function number, as for example, 52CS, 71W, or 49D. When it is necessary to use two types of suffix letters in connection with one function number, it is often desirable for clarity to separate them by a slanted line or dash, as for example, 20D/CS or 20D-CS.

The suffix letters which denote parts of the main device, and those which cannot or need not form part of the device function designation, are generally written directly below the device function number on drawings, as for

example, $\frac{52}{CC}$ or $\frac{43}{A}$.

IEEE device numbers and functions (cont'd)

Auxiliary devices Separate auxiliary devices

X	
Y	– Auxiliary relay ¹⁾
Z	
R	– Raising relay
L	– Lowering relay
O	– Opening relay or contactor
C	– Closing relay or contactor
CS	– Control switch
CL	– Auxiliary relay, open (energized when main device is in open position)
OP	– Auxiliary relay, open (energized when main device is in open position)
U	– “Up” position-switch relay
D	– “Down” position-switch relay
PB	– Push button

1) In the control of a circuit breaker with so-called X-Y relay control scheme, the X relay is the device whose main contacts are used to energize the closing coil or the device which in some other manner, such as by the release of stored energy, causes the breaker to close. The contacts of the Y relay provide the anti-pump feature for the circuit breaker.

Actuating quantities

These letters indicate the **condition or electrical** quantity to which the device responds, or the medium in which it is located, such as:

A	– Air or Amperes or Alternating
C	– Current
D	– Direct or Discharge
E	– Electrolyte
F	– Frequency, or Flow, or Fault
H	– Explosive
J	– Differential
L	– Level, or Liquid
P	– Power, or Pressure
PF	– Power factor
Q	– Oil
S	– Speed, or Suction, or Smoke
T	– Temperature
V	– Voltage, Volts, or Vacuum
VAR	– Reactive power
VB	– Vibration
W	– Water, or Watts

Main devices

These letters denote the **location of the main device in the circuit**, or the type of circuit in which the device is used or the type of circuit or apparatus with which it is associated, when this is necessary, such as:

A	– Alarm or Auxiliary power
AN	– Anode
B	– Battery, or Blower, or Bus
BK	– Brake
BL	– Block (Valve)
BP	– Bypass
BT	– Bus tie
C	– Capacitor, or Condenser, or Compensator, or Carrier current, or Case, or Compressor
CA	– Cathode
CH	– Check (Valve)
D	– Discharge (Valve)
E	– Exciter
F	– Feeder, or Field, or Filament, or Filter, or Fan
G	– Generator, or Ground ²⁾
H	– Heater, or Housing
L	– Line, or Logic
M	– Motor, or Metering
N	– Network, or Neutral ²⁾
P	– Pump, or Phase comparison
R	– Reactor, or Rectifier, or Room
S	– Synchronizing, or Secondary, or Strainer, or Sump, or Suction (Valve)
T	– Transformer, or Thyatron
TH	– Transformer (high-voltage side)
TL	– Transformer (low-voltage side)
TM	– Telemeter
U	– Unit

2) Suffix “N” is generally used in preference to “G” for devices connected in the secondary neutral of current transformers, or in the secondary of a current transformer whose primary winding is located in the neutral of a machine or power transformer, except in the case of transmission line relaying, where the suffix “G” is more commonly used for those relays which operate on ground faults.

Main device parts

These letters denote **parts of the main device**, divided in the two following categories:

1. All parts, except auxiliary contacts, position switches, limit switches, and torque limit switches.

BK	– Brake
C	– Coil, or Condenser, or Capacitor
CC	– Closing coil
HC	– Holding coil
M	– Operating motor
MF	– Fly-ball motor
ML	– Load-limit motor
MS	– Speed adjusting, or Synchronizing motor
S	– Solenoid
SI	– Seal-in
TC	– Trip coil
V	– Valve

2. All auxiliary contacts and positioning and limit switches for such devices and equipment as circuit breakers, contactors, valves and rheostats and contacts of relays. These are designated as follows:

a	– Contact that is open when the main device is in the standard reference position, commonly referred to as the nonoperated or deenergized position, and that closes when the device assumes the opposite position.
b	– Contact that is closed when the main device is in the standard reference position, commonly referred to as the nonoperated or deenergized position, and that opens when the device assumes the opposite position.
aa	– Contact that is open when the operating mechanism of the main device is in the nonoperated position and that closes when the operating mechanism assumes the opposite position.
bb	– Contact that is closed when the operating mechanism of the main device is in the nonoperated position and that opens when the operating mechanism assumes the opposite position.

Standard reference positions of some typical devices are as follows:

Device	Standard reference position
Power circuit breaker	Main contacts open
Disconnecting switch	Main contacts open
Load-break switch	Main contacts open
Valve	Closed position
Gate	Closed position
Clutch	Disengaged position
Turning gear	Disengaged position
Power electrodes	Maximum gap position
Rheostat	Maximum resistance position
Adjusting means ¹⁾	Low or Down position
Relay ²⁾	Deenergized position
Contactator ²⁾	Deenergized position
Relay (latched-in type)	Non-latched-in position
Contactator (latched-in type)	Main contacts open
Temperature relay ³⁾	Lowest temperature
Level detector ³⁾	Lowest level
Flow detector ³⁾	Lowest flow
Speed switch ³⁾	Lowest speed
Vibration detector ³⁾	Minimum vibration
Pressure switch ³⁾	Lowest pressure
Vacuum switch ³⁾	Lowest pressure, i.e., highest vacuum

The simple designation “a” or “b” is used in all cases where there is no need to adjust the contacts to change position at any particular point in the travel of the main device or where the part of the travel where the contacts change position is of no significance in the control or operating scheme. Hence the “a” and “b” designations usually are sufficient for circuit breaker auxiliary switches.

Note: If several similar auxiliary switches are present on the same device, they should be designated numerically 1, 2, 3, etc. when necessary.

IEEE device numbers and functions (cont'd)

Device	Standard reference position
1) These may be speed, voltage, current, load, or similar adjusting devices comprising rheostats, springs, levers, or other components for the purpose.	
2) These electrically operated devices are of the non-latched-in type, whose contact position is dependent only upon the degree of energization of the operating or restraining or holding coil or coils which may or may not be suitable for continuous energization. The deenergized position of the device is that with all coils deenergized.	
3) The energizing influences for these devices are considered to be, respectively, rising temperature, rising level, increasing flow, rising speed, increasing vibration, and increasing pressure.	

D	– Decelerating, or Detonate, or Down, or Disengaged
E	– Emergency, or Engaged
F	– Failure, or Forward
H	– Hot, or High
HR	– Hand reset
HS	– High speed
L	– Left, or Local, or Low, or Lower, or Leading
M	– Manual
OFF	– Off
ON	– On
P	– Polarizing
R	– Right, or Raise, or Reclosing, or Receiving, or Remote, or Reverse
S	– Sending, or Swing
T	– Test, or Trip, or Trailing
TDC	– Time-delay closing
TDO	– Time-delay opening
U	– Up

Other switches

These letters cover **all other distinguishing features or characteristics or conditions**, which serve to describe the use of the device or its contacts in the equipment such as:

A	– Accelerating, or Automatic
B	– Blocking, or Back-up
C	– Close, or Cold