

MEDIUM VOLTAGE PRODUCT

ADVASENSE™ KEVCD A

Indoor Combined Sensor



Parameters for Application	Value
Rated primary current of application	up to 1 250 A
Rated primary voltage of application	up to 24/ $\sqrt{3}$ kV
Sensor Parameters	Value
Rated primary voltage, U_{pr}	11/ $\sqrt{3}$ kV 15/ $\sqrt{3}$ kV 22/ $\sqrt{3}$ kV
Highest voltage for equipment, U_m	12 kV 17.5 kV 24 kV
Rated power frequency withstand voltage	28 (42) kV 38 kV 50 kV
Rated lightning impulse withstand voltage	75 kV 95 kV 125 kV
Rated primary current, I_{pr}	80 A
Rated continuous thermal current, I_{cth}	1 250 A
Rated transformation ratio, K_{ra} for current measurement	80 A / 150 mV at 50 Hz 180 mV at 60 Hz
Rated transformation ratio, K_n for voltage measurement	10 000 : 1
Current accuracy class	0.5/5P630 (IEC 60044-8) 0.5/5P 50 kA (IEC 61869-10)
Voltage accuracy class	0.5/3P
Length of cable	5.0; 6.5; 7.5 m

Sensor principles

The AdvaSense™ combined sensor (Electronic current transformers according to IEC 60044-8, low-power passive current transformers according to IEC 61869-10 standard, Electronic

voltage transformer according to IEC 60044-7 and low-power passive voltage transformers according to IEC 61869-11) offer an alternative way of making the current and voltage measurements needed for the protection and monitoring of medium voltage power systems. Sensors based on alternative principles have been introduced as successors to conventional instrument transformers to significantly reduce size, increase safety, and to provide greater rating standardization and a wider functionality range. These well-known principles can only be fully utilized in combination with versatile electronic relays.

Sensor characteristics

Construction of ABB's combined sensor is done without the use of a ferromagnetic core. This fact results in several important benefits for the user and the application.

The main benefit is that the behavior of the sensor is not influenced by non-linearity and width of hysteresis curve, which results in a highly accurate and linear response over a wide dynamic range of measured quantities. A linear and highly accurate sensor characteristic in the full operating range enables the combination of metering and protection classes in one winding.

With KEVCD A sensor measuring **class 0.5** is reached for continuous current measurement in the extended accuracy range from 5% of the rated primary current I_{pr} **not only up to 120% of I_{pr}** (as being common for conventional current transformers), **but even up to the rated continuous thermal current I_{cth}** . For dynamic current measurement (protection purposes) the ABB sensor KEVCD A fulfills requirements of protection class **5P up to an impressive value reaching the rated short-time thermal current I_{th}** . That provides the possibility to designate the corresponding accuracy class **as 5P630 (IEC 60044-8) and 5P 50 kA (IEC 61869-10)**, proving excellent linearity and accuracy measurements.

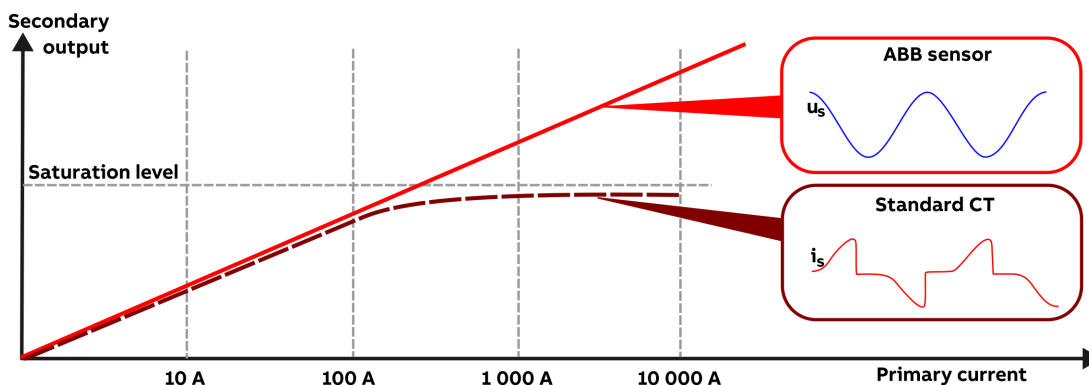

O1 Example of sensor characteristic and current characteristic

Current sensor

Current measurement in KEVCD A sensors is based on the Rogowski coil principle. A Rogowski coil is a toroidal coil, without an iron core, placed around the primary conductor in the same way as the secondary winding in a current transformer. However, the output signal from a Rogowski coil is not a current, but a voltage:

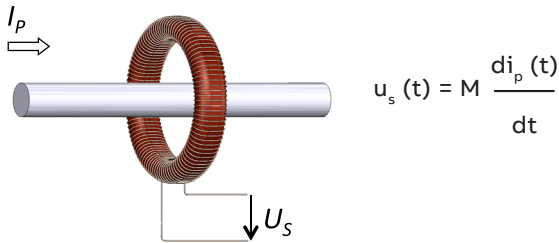

O2 Rogowski coil principle

In all cases, a signal that represents the actual primary current waveform is easily obtained by integrating the transmitted output signal.

Voltage sensor

Voltage measurement in KEVCD A sensors is based on the resistive divider principle. The output voltage is directly proportional to the input voltage:

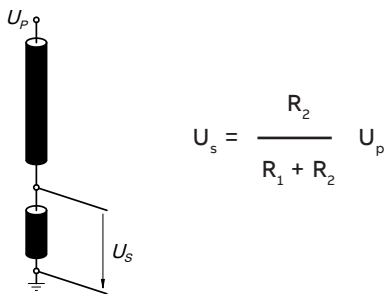

O3 Resistive divider principle

In all cases, the transmitted output signal reproduces the actual waveform of the primary voltage signal.

Protection and control IEDs (Intelligent Electronic Devices)

Protection and control IEDs incorporate the functions of a traditional relay, as well as allow new additional functions. The information transmitted from the sensors to the IED is very accurate, providing the possibility of versatile relay functionality. However, the IED must be able to operate with sufficient accuracy at a sensor's low input signal level, and the signal from the Rogowski coil must be integrated. Modern IEDs (such as ABB's Relion® 615 series relays) are designed for such sensor use, and they are also equipped with built-in integrators for Rogowski coil sensor inputs. Modern digital apparatuses (microprocessor based relays) allow protection and measurement functions to be combined. They fully support current and voltage sensing realized by the single sensor with double the accuracy class designation (e.g.: current sensing with combined accuracy class 0.5/5P630 according to IEC 60044-8 and 0.5/5P 50 kA according to IEC 61869-10 as well as voltage sensing with combined accuracy class 0.5/3P).



O4 Sensor and IED

Sensor design

KEVCD A is a block type sensor designed according to the DIN 42600 size requirements. Two versions could be selected: one providing current measurement together with voltage indication capability, or a second one, providing, in addition to these, also the possibility of voltage measurement.

SENSOR VARIANTS

Type designation	Functions included		
	Voltage sensor	Current sensor	Voltage indication
KEVCD 12 AE3	•	•	•
KEVCD 12 AG3		•	•
KEVCD 17.5 AE3	•	•	•
KEVCD 17.5 AG3		•	•
KEVCD 24 AE3	•	•	•
KEVCD 24 AG3		•	•

Differences between Sensors and Instrument Transformers

There are some noticeable differences between Sensors and conventional Instrument Transformers:

Linearity

Due to the absence of a ferromagnetic core the sensor has a linear response over a very wide primary current range, far exceeding the typical CT range. Thus, current sensing for both measurement and protection purposes could be realized with single secondary winding with a double rating. In addition, one standard sensor can be used for a broad range of rated currents and is also capable of precisely transferring signals containing frequencies different from rated ones.

For this type of sensor, the variation of amplitude and phase error or composite error in a current range from 5% of rated primary current I_{pr} up to the rated short-time thermal current I_{th} is within the limits specified by IEC 60044-8 and IEC 61869-10.

Example of current measurement range with rated current 80 A and accuracy class 0.5/5P630 (IEC 60044-8) and 0.5/5P 50 kA (IEC 61869-10):

Metering accuracy class 0.5 is, according to the IEC 60044-8 and IEC 61869-10 standards, guaranteed from 5% of I_{pr} up to $K_{pcr} \times I_{pr}$ where K_{pcr} is rated extended primary current factor and I_{pr} is rated primary current. Factor K_{pcr} is in the case of conventional CTs usually just 1.2, but in the case of the KEVCD A sensor the K_{pcr} factor is several times higher and equals 15.625. Protection accuracy 5P630 (IEC 60044-8) and 5P 50 kA (IEC 61869-10) is guaranteed, for the advanced KEVCD A sensor, from the current equal to $K_{pcr} \times I_{pr}$ up to the current corresponding to $K_{alf} \times I_{pr}$ value, where K_{alf} is, according to IEC 60044-8 and IEC 61869-10, the accuracy limit factor. For this type of sensor the value of $K_{pcr} \times I_{pr}$ is equal to the rated continuous thermal current I_{cth} (1250 A) and the value of $K_{alf} \times I_{pr}$ is equal to the rated short-time thermal current I_{th} (50 kA). The accuracy limits are described on the graph below.

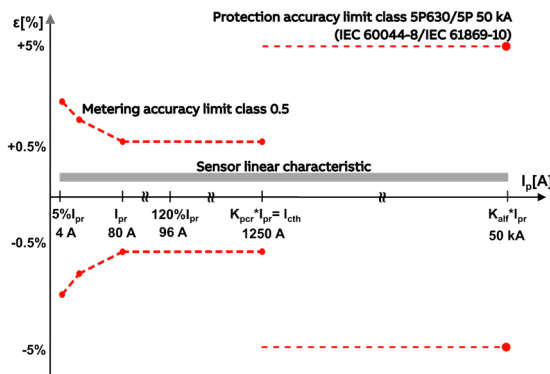

O5 Example of combined accuracy class for current measurement

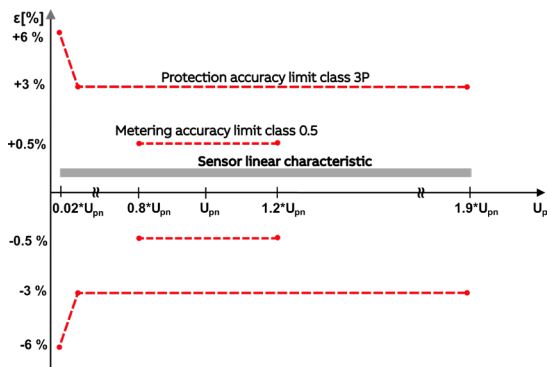

O6 Example of combined accuracy class for voltage measurement

Compactness

Since the sensing elements are particularly small, and the same elements are used for both measurement and protection, the current and voltage sensors can easily be combined in one device – the Combined Sensor, which is still smaller and far lighter than the conventional Instrument Transformer. The weight of the combined KEVCD A sensor designed for 24kV is only 15.6 kg and designs for lower voltage levels are even lighter. This enables much easier handling without the need for special lifting devices.

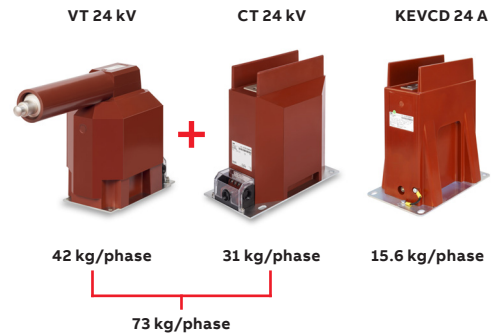

O7 Combined sensors

Rated parameters

Because the sensors are highly linear within a very wide range of currents and voltages, the same single sensor can be used for the various rated currents and voltages associated with each specific application up to the specified maximum voltage for equipment. There is no need to specify other parameters such as burden, safety factor, etc. since they are standard over the defined range. To achieve the correct function of the protection and control IED, the selected rated current and voltage, as well as the rated transformation ratio, must be properly set into the IED.

Energy savings concept

As there is no iron core, no necessity for high burden values and thus a possibility for low current losses and only one secondary winding needed, KEVCD A sensors exhibit extremely low energy consumption that is just a fraction of that transferred to heat in conventional CTs/VTs. This fact contributes to huge energy savings during its entire operating life, supporting the world-wide effort to reduce energy consumption.

Furthermore, the temperature rise caused by internal heating up due to current flowing through the sensor is very low and creates a further possibility of upgrading current ratings of the switchgear, or the other applications, and/or reduces the need for artificial ventilation.

Correction factors

The amplitude and phase error of a current and a voltage sensor is, in practice, constant and independent of the primary current and primary voltage. Due to this fact it is an inherent and constant property of each sensor and it is not considered as unpredictable and influenced error. Hence, it can be easily corrected in the IED by using appropriate correction factors, stated separately for every sensor. Values of the correction factors for the amplitude and phase error of a current and a voltage sensor are mentioned on the sensor label (for more informations please refer to the Instructions for installation, use and maintenance) and should be uploaded without any modification into the IED before the sensors are put into operation (please check available correction in the IED manual). To achieve required accuracy classes it is recommended to use all correction factors (Cfs): amplitude correction factor (aI/CFI) and phase error correction factor ($pI/\varphi_{0\text{cor}}$) of a current sensor and amplitude correction factor (aU/CFU) and phase error correction factor ($pU/\varphi_{0\text{cor}}$) of a voltage sensor.

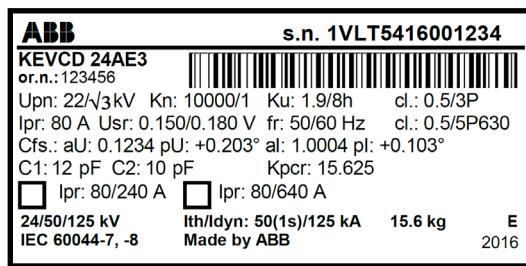

08 Example of a sensor label according to IEC 60044-7,-8

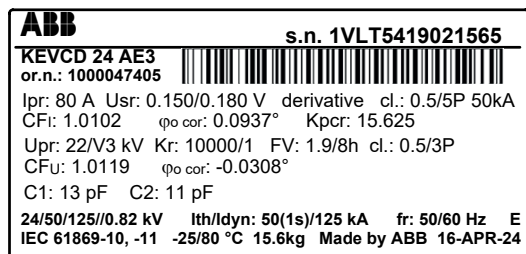

09 Example of a sensor label according to IEC 61869-10,-11

Secondary cables

The sensor is equipped with a cable for connection with the IED. The cable connector is type RJ-45. The sensor accuracy classes are verified up to the RJ-45 connector, i.e. considering also its secondary cable. These cables are intended to be connected directly to the IED, and subsequently neither burden calculation nor secondary wiring is needed. Every sensor is therefore accuracy tested when equipped with its own cable and connector. The polarity of the sensor is determined just by the type of the used cable. The polarity of the sensor could be normal (P1-P2) or reverse (P2-P1) depending on the used cable. Standard cable lengths: 5.0; 6.5 and 7.5 m

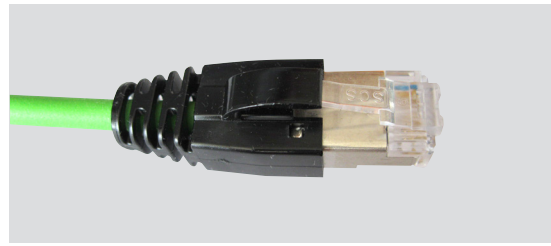

10 Connector RJ-45 (IEC 60044-7, IEC 60044-8)

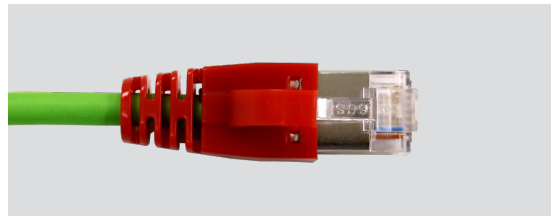

11 Connector RJ-45 (IEC 61869-10, IEC 61869-11)

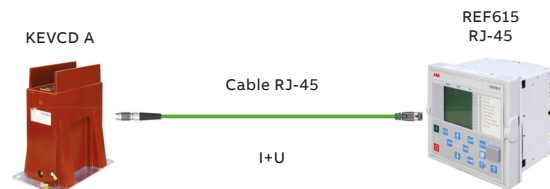

12 Direct connection between the sensor and IED

Current adapters

If the transmitted signal from the current sensor is too high to be processed properly by the IED, a current adapter is to be inserted between the sensor cable and the IED adapter unit. Simply said, the current adapter operates as a highly accurate voltage divider giving a higher transformation ratio of the current sensor. The current adapters have to be matched to the actually used IED and must be ordered as accessories. For IEDs from the Relion® product family (REX615, etc.) no current adapter is needed. The current range could be changed in the IED using a higher transformation ratio parameter.

Rated primary current of application	Current adapter to be used	Resulting transformation ratio at 50Hz (60Hz)	Maximal linearity limit
(80 – 160) A	Not needed	80 A/150 mV (180 mV)	4 000 A
(160 – 480) A	AR1/240 AR2/240	240 A/150 mV (180 mV)	12 000 A
(480 – 1250) A	AR1/640 AR2/640	640 A/150 mV (180 mV)	32 000 A

Connector adapters

To provide connectivity between a sensor with a RJ-45 cable connector and IEDs with Twin-BNC connectors a group of adapters were designed. The use of an adapter has no influence on the current and/or voltage signal and accuracy of the sensor with the cable.

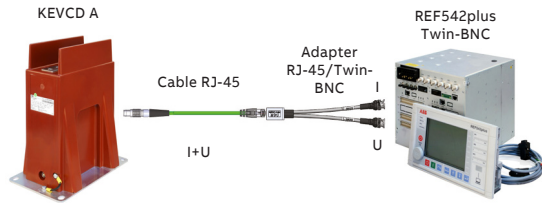

13 Connection between sensor and IED which requires adapter

For more information about current adapters and connector adapters refer to Doc. No. 1VLC000710 - Sensor Accessories.

Coupling electrode for voltage detection system

Intended to be used in:

- Voltage detection system (VDS) and Voltage presence indication system (VPIS) according to IEC 62271-213

If there is no connection of the coupling electrode to the coupling system the electrode must be earthed. The sensor is delivered with an earthed coupling electrode.

CAPACITANCE VALUES

Electrode	Sensor highest voltage for equipment	
	12 and 17.5 kV	24 kV
C1	(23 – 40) pF	(10 – 18) pF
C2	≤90 pF	≤ 90 pF

Standards

General

IEC 61869-6 (2016-04) Instrument transformers - Part 6: Additional general requirements for low-power instrument transformers

Voltage sensors:

IEC 60044-7 (1999-12) Instrument transformers – Part 7: Electronic voltage transformers

IEC 61869-11 (2017-12) Instrument transformers - Part 11: Additional requirements for low-power passive voltage transformers

Current sensors:

IEC 60044-8 (2002-07) Instrument transformers – Part 8: Electronic current transformers

IEC 61869-10 (2017-12) Instrument transformers - Part 10: Additional requirements for low-power passive current transformers

Sensor name code

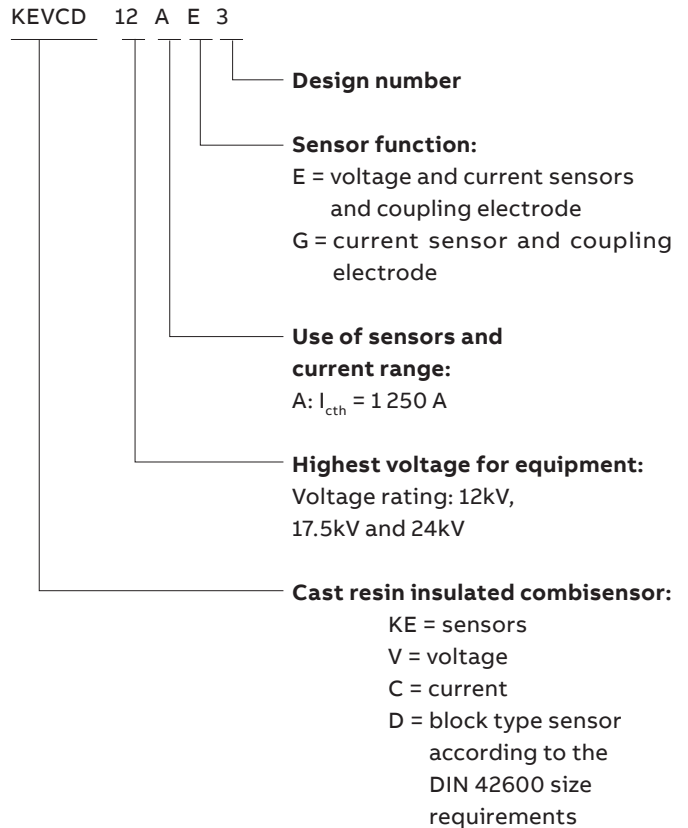

Temperature category

- Operation: - 25°C/+80°C
- Transport and storage: -40°C/+80°C

Cable

- Length: 5.0; 6.5; 7.5 m
- Connector: RJ-45 (CAT-6)

Ordering data / specification of sensor

- Rated primary current of application
- Used IED
- Accessories (Current adapter; Connector adapter)

COMBINED SENSOR PARAMETERS

	Standard	KEVCD 12	KEVCD 17.5	KEVCD 24
Highest voltage for equipment and test voltages				
Highest voltage for equipment, U_m	IEC 60044-7/8 IEC 61869-10/11	12 kV	17.5 kV	24 kV
Rated power frequency test voltage	IEC 60044-7/8 IEC 61869-10/11	28 (42) kV	38 kV	50 kV
Rated lightning impulse test voltage	IEC 60044-7/8 IEC 61869-10/11	75 kV	95 kV	125 kV
Insulation requirements for secondary terminals according to IEC 61869-6				
Power frequency voltage withstand capability	IEC 61869-6		0.82 kV	
Impulse voltage withstand capability	IEC 61869-6		1.5 kV 1.2/50 μ s	
Voltage sensor, rated values				
Rated primary voltage U_{pn}	IEC 60044-7 IEC 61869-11	11/ $\sqrt{3}$ kV	15/ $\sqrt{3}$ kV	22/ $\sqrt{3}$ kV
Maximum rated primary voltage U_{pnmax}	IEC 60044-7 IEC 61869-11	12/ $\sqrt{3}$ kV	17.5/ $\sqrt{3}$ kV	24/ $\sqrt{3}$ kV
Rated frequency, f_n	IEC 60044-7 IEC 61869-11		50/60 Hz	
Accuracy class	IEC 60044-7 IEC 61869-11		0.5/3P	
Rated burden, R_{br}	IEC 60044-7		10 M Ω	
	IEC 61869-11		2 M Ω / 50 pF	
Rated transformation ratio, K_n	IEC 60044-7 IEC 61869-11		10 000 : 1	
Rated voltage factor, k_u	IEC 60044-7 IEC 61869-11		1.9/8 h	
Current sensor, rated values				
Rated primary current, I_{pr}	IEC 60044-8 IEC 61869-10		80 A	
Rated transformation ratio, K_{ra}	IEC 60044-8 IEC 61869-10		80 A/150 mV at 50 Hz 80 A/180 mV at 60 Hz	
Rated secondary output, U_{sr}	IEC 60044-8 IEC 61869-10		3 mV/Hz i.e. 150 mV at 50 Hz or 180 mV at 60 Hz	
Rated continuous thermal current, I_{cth}	IEC 60044-8 IEC 61869-10		1250 A	
Rated short-time thermal current, I_{th}	IEC 60044-8 IEC 61869-10		50 kA/1 s	
Rated dynamic current, I_{dyn}	IEC 60044-8 IEC 61869-10		125 kA	
Rated frequency, f_r	IEC 60044-8 IEC 61869-10		50/60 Hz	
Rated extended primary current factor, K_{pcr}	IEC 60044-8 IEC 61869-10		15.625	
Accuracy limit factor, K_{alf}	IEC 60044-8 IEC 61869-10		630	
Accuracy class	IEC 60044-8		0.5/5P 630	
	IEC 61869-10		0.5/5P 50kA	
Rated burden, R_{br}	IEC 60044-8		10 M Ω	
	IEC 61869-10		2 M Ω / 50 pF	

Note: For KEVCD 12 the extended rated power frequency test voltage 42 kV shall be specified.

ORDERING DATA FOR KEVCD A SENSOR

Polarity	Standard	Lenght			
		5 m	6.5 m	7.5 m	
P1-P2	IEC 60044 7/8	KEVCD 12 AE3	1VL5400018V0101	1VL5400018V0110	1VL5400018V0119
		KEVCD 17.5 AE3	1VL5400020V0101	1VL5400020V0110	1VL5400020V0119
		KEVCD 24 AE3	1VL5400022V0101	1VL5400022V0110	1VL5400022V0119
		KEVCD 12 AG3	1VL5400024V0101	1VL5400024V0110	1VL5400024V0119
		KEVCD 17.5 AG3	1VL5400026V0101	1VL5400026V0110	1VL5400026V0119
		KEVCD 24 AG3	1VL5400028V0101	1VL5400028V0110	1VL5400028V0119
P2 - P1	IEC 60044 7/8	KEVCD 12 AE3	1VL5400019V0101	1VL5400019V0110	1VL5400019V0119
		KEVCD 17.5 AE3	1VL5400021V0101	1VL5400021V0110	1VL5400021V0119
		KEVCD 24 AE3	1VL5400023V0101	1VL5400023V0110	1VL5400023V0119
		KEVCD 12 AG3	1VL5400025V0101	1VL5400025V0110	1VL5400025V0119
		KEVCD 17.5 AG3	1VL5400027V0101	1VL5400027V0110	1VL5400027V0119
		KEVCD 24 AG3	1VL5400029V0101	1VL5400029V0110	1VL5400029V0119
P1 - P2	IEC 61869 10/11	KEVCD 12 AE3	1VL5400018V1101	1VL5400018V1110	1VL5400018V1119
		KEVCD 17.5 AE3	1VL5400020V1101	1VL5400020V1110	1VL5400020V1119
		KEVCD 24 AE3	1VL5400022V1101	1VL5400022V1110	1VL5400022V1119
		KEVCD 12 AG3	1VL5400024V1101	1VL5400024V1110	1VL5400024V1119
		KEVCD 17.5 AG3	1VL5400026V1101	1VL5400026V1110	1VL5400026V1119
		KEVCD 24 AG3	1VL5400028V1101	1VL5400028V1110	1VL5400028V1119
P2 - P1	IEC 61869 10/11	KEVCD 12 AE3	1VL5400019V1101	1VL5400019V1110	1VL5400019V1119
		KEVCD 17.5 AE3	1VL5400021V1101	1VL5400021V1110	1VL5400021V1119
		KEVCD 24 AE3	1VL5400023V1101	1VL5400023V1110	1VL5400023V1119
		KEVCD 12 AG3	1VL5400025V1101	1VL5400025V1110	1VL5400025V1119
		KEVCD 17.5 AG3	1VL5400027V1101	1VL5400027V1110	1VL5400027V1119
		KEVCD 24 AG3	1VL5400029V1101	1VL5400029V1110	1VL5400029V1119

Dimensional Drawing

KEVCD 12
KEVCD 17.5

Drawing No.: 1VL5300733R0101

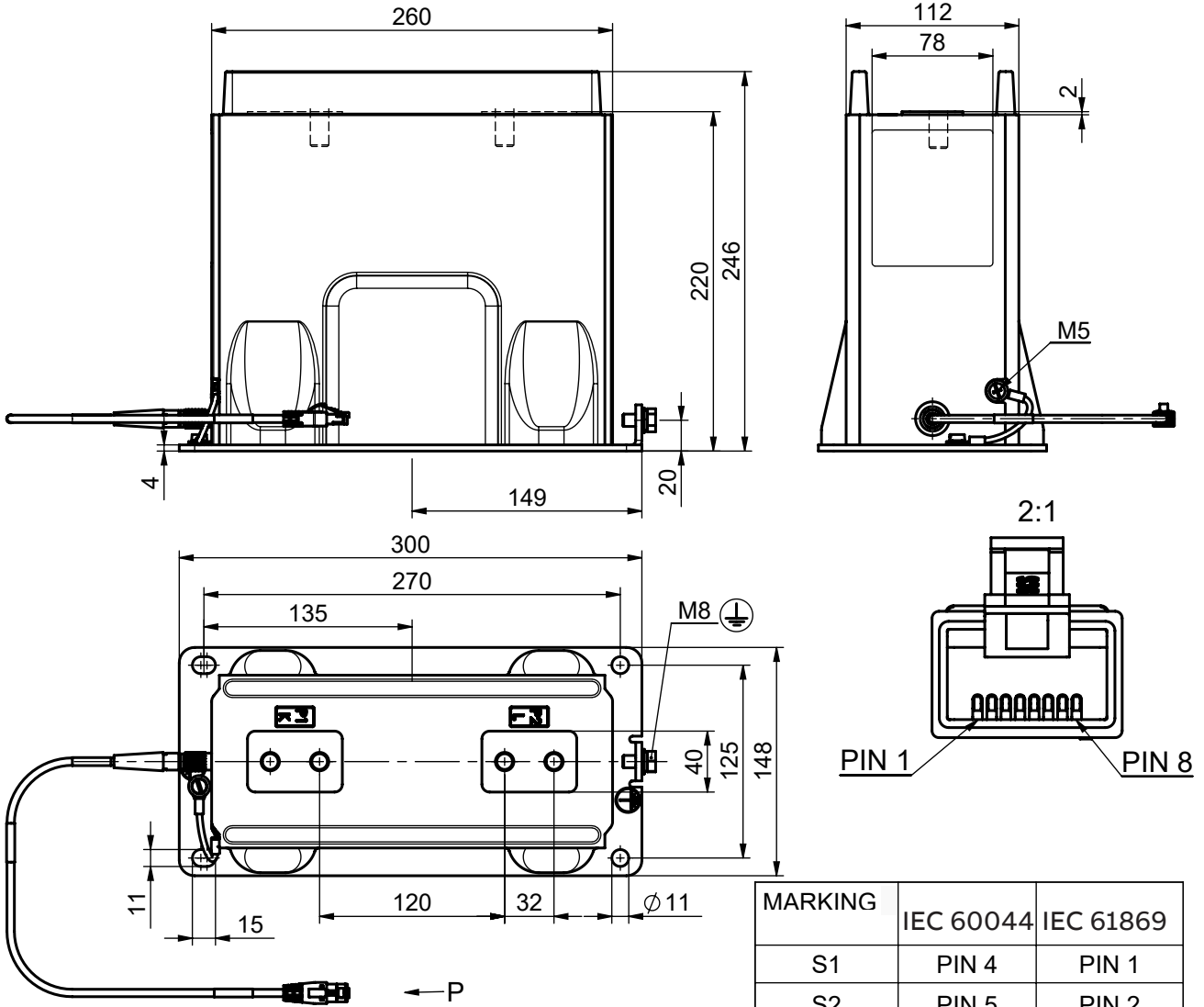

MARKING	IEC 60044	IEC 61869
S1	PIN 4	PIN 1
S2	PIN 5	PIN 2
a	PIN 7	
n	PIN 8	

ONLY FOR TYPE AE

Dimensional Drawing

KEVCD 24

Drawing No.: 1VL5300734R0101

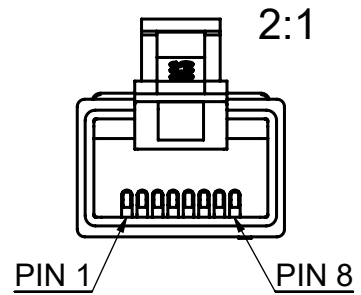
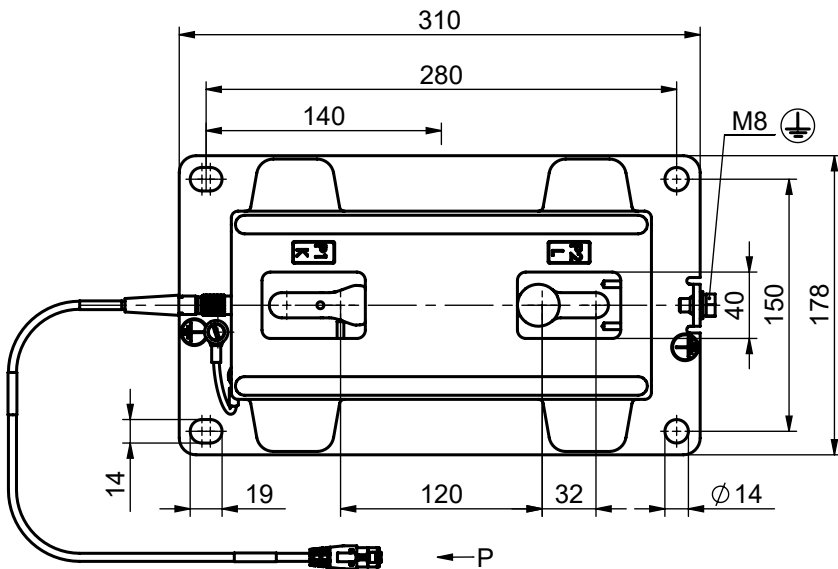
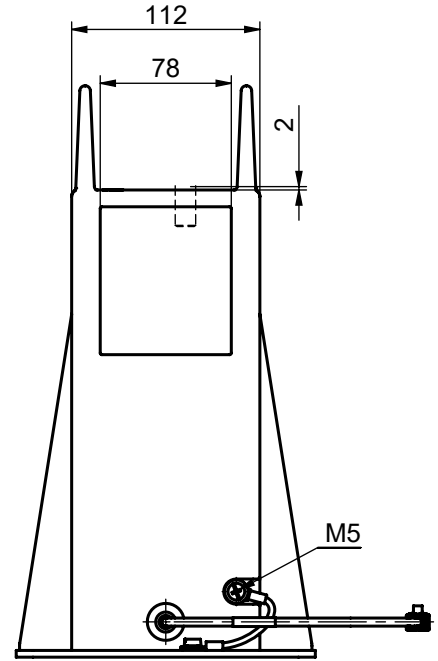
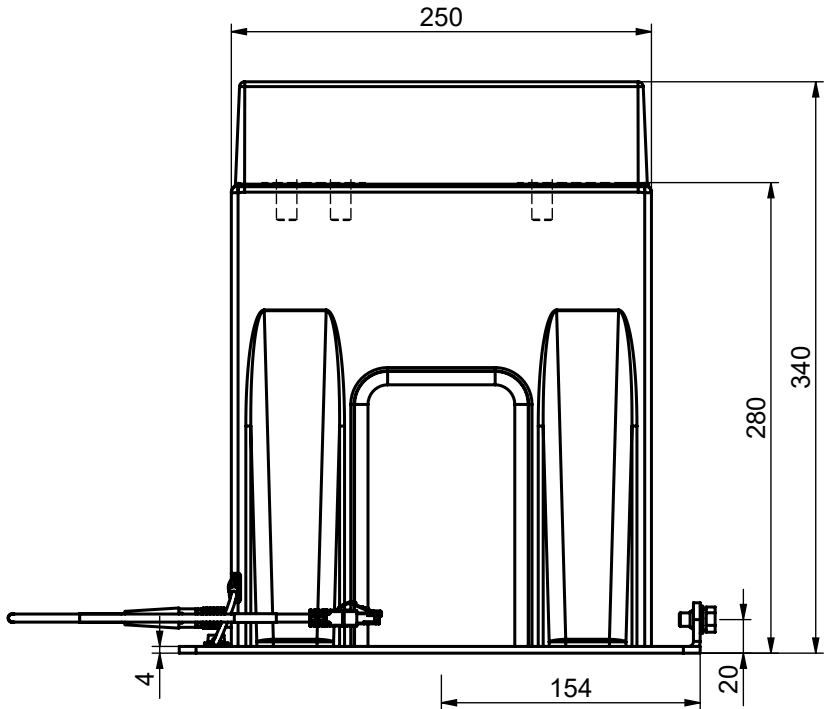

MARKING	IEC 60044	IEC 61869
S1	PIN 4	PIN 1
S2	PIN 5	PIN 2
a	PIN 7	
n	PIN 8	

ONLY FOR TYPE AE



CONTACT US

ABB s.r.o.

ELDS Brno

Videnska 117, 619 00 Brno,
Czech Republic

Tel.: +420 547 152 021
+420 547 152 854

E-mail: kontakt@cz.abb.com

www.abb.com

NOTE

We reserve the right to make technical changes or modify the contents of this document without prior notice. With regard to purchase orders, the agreed particulars shall prevail. ABB does not accept any responsibility whatsoever for potential errors or possible lack of information in this document.

We reserve all rights in this document and in the subject matter and illustrations contained therein. Any reproduction, disclosure to third parties or utilization of its contents - in whole or in parts - is forbidden without prior written consent of ABB.

Copyright© 2025 ABB
All rights reserved