

MEDIUM VOLTAGE PRODUCT

# AdvaSense™ KECA 80 C104; KECA 80 C165

## Indoor Current Sensor



## 01 Sensor characteristics

Parameters for Application	Value
Rated primary current of application	up to 1 250/4 000 A
Sensor Parameters	Value
Highest voltage for equipment, $U_m$	0.72 kV
Rated power frequency withstand voltage	3 kV
Rated primary current, $I_{pr}$	80 A
Rated continuous thermal current, $I_{cth}$	1 250 A 4 000 A
Rated transformation ratio, $K_{ra}$	80 A/ 150 mV at 50 Hz 180 mV at 60 Hz
Current accuracy class: IEC 60044-8	0.5/5P400 0.5/5P630
IEC 61869-10	0.5-A2/5P 85kA
Length of cable	5 m

### Sensor principles

Electronic Instrument Transformers (Sensors) offer an alternative way of making the current measurements needed for the protection and monitoring of medium voltage power systems. AdvaSense™ Sensors based on alternative principles have been introduced as successors to conventional instrument transformers in order to significantly reduce size, increase safety, and to provide greater rating standardization and a wider functionality range. These well known principles can only be fully utilized in combination with versatile electronic relays.

### Sensor characteristics

Construction of ABB's AdvaSense™ current sensors is done without the use of a ferromagnetic core. This fact results in several important benefits for the user and the application.

The main benefit is that the behavior of the sensor is not influenced by non-linearity and the width of the hysteresis curve, which results in a highly accurate and linear response over a wide dynamic range of measured quantities.

A linear and highly accurate sensor characteristic in the full operating range enables the combination of metering and protection classes in one winding. With KECA 80 Cxxx sensors measuring **class 0.5** is reached for continuous current measurement in the extended accuracy range from 5% of the rated primary current  $I_{pr}$  **not only up to 120% of  $I_{pr}$**  (as being common for conventional current transformers), **but even up to the rated continuous thermal current  $I_{cth}$** . For dynamic current measurement (protection purposes) the ABB sensors KECA 80 Cxxx fulfill requirements of protection class **5P up to an impressive value reaching the rated short-time thermal current  $I_{th}$** . That provides the possibility to designate the corresponding accuracy class as **0.5/5P400** and **0.5/5P630** (IEC 60044-8) or **0.5-A2/5P 85kA** (IEC61869-10), proving excellent linearity and accuracy measurements.

### Current sensor

Current measurement in KECA 80 Cxxx sensors is based on the Rogowski coil principle. A Rogowski coil is a toroidal coil, without an iron core, placed around the primary conductor in the same way as the secondary winding in a current transformer. However, the output signal from a Rogowski coil is not a current, but a voltage:

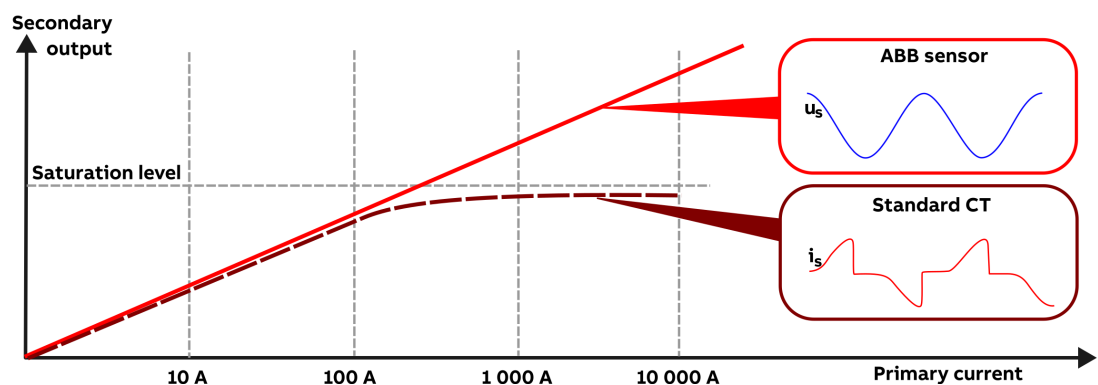

—  
02 Rogowski coil principle

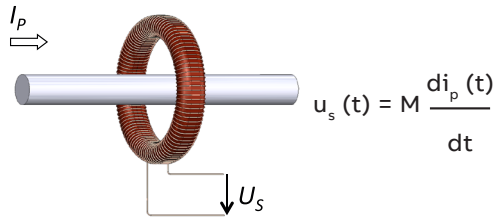

—  
03 IED and sensor

—  
04 Current sensors installed in MV air insulated switchgear UniGear ZS1 12/17.5 kV

—  
02

In all cases, a signal that represents the actual primary current waveform is easily obtained by integrating the transmitted output signal.

**Protection and control IEDs (Intelligent Electronic Devices)**

Protection and control IEDs incorporate the functions of a traditional relay, as well as allow new additional functions. The information transmitted from the sensors to the IED is very accurate, providing the possibility of versatile relay functionality.

However, the IED must be able to operate with sufficient accuracy at a sensor's low input signal level, and the signal from the Rogowski coil must be integrated. Modern IEDs (such as ABB's 615 series relays) are designed for such sensor use, and they are also equipped with built-in integrators for Rogowski coil sensor inputs.

Modern digital apparatuses (microprocessor based relays) allow protection and measurement functions to be combined. They fully support current sensing realized by the single sensor with double the accuracy class designation (e.g.: current sensing with combined accuracy class 0.5/5P400 and 0.5/5P630 (IEC 60044-8) or 0.5-A2/5P 85kA (IEC61869-10)).



—  
03

**Sensor applications**

The current sensors type KECA 80 C104 and KECA 80 C165 are intended for use in current measurement in medium voltage air insulated switchgear type UniGear ZS1 12/17.5 kV as well as in OneFit hard-bus retrofill design concept for MV circuit breakers.

**The sensors are intended only for factory installation.**

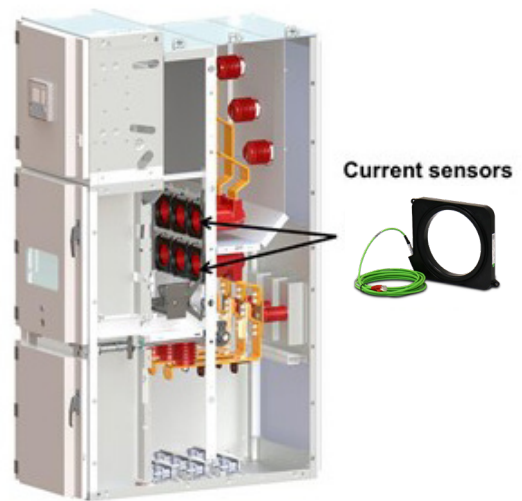

—  
04

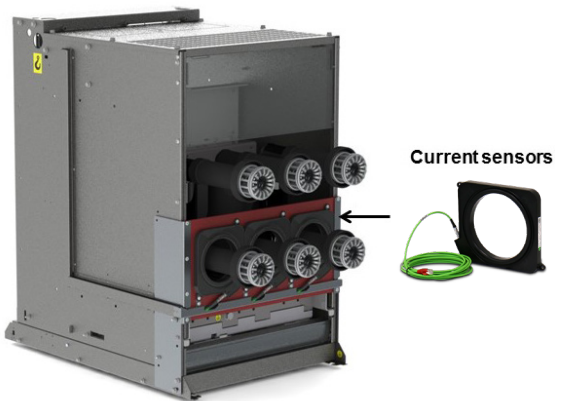

—  
05

**Note: For use in other application please contact ABB.**

**Differences between Sensors and Instrument Transformers**

There are some noticeable differences between Sensors and conventional Instrument Transformers:

**Linearity**

Due to the absence of a ferromagnetic core the sensor has a linear response over a very wide primary current range, far exceeding the typical CT range. Thus, current sensing for both measurement and protection purposes could be realized with single secondary winding with a double rating. In addition, one standard sensor can be used for a broad range of rated currents and is also capable of precisely transferring signals containing frequencies different from rated ones.

For this type of sensor, the variation of amplitude and phase error or composite error in a current range from 5% of rated primary current  $I_{pr}$  up to the rated short-time thermal current  $I_{th}$  is within the limits specified by IEC 60044-8 and IEC 61869-10.

06 Combined accuracy class

07 Example of a sensor label (IEC 60044-8 without UL certification)

08 Example of a sensor label (IEC 61869-10 with UL certification)  
- Upper label - part of accessories, to be glued to Switchgear  
- Bottom label with UL logo - placed on sensor

09 Connector RJ-45

**Example of current measurement range with rated current 80 A and accuracy class 0.5/5P400 and 0.5/5P630 (IEC 60044-8) or 0.5-A2/5P 85kA (IEC61869-10):**

Metering accuracy class 0.5 is, according to the IEC 60044-8 and IEC 61869-10 standard, guaranteed from 5% of  $I_{pr}$  up to  $K_{pcr} \times I_{pr}$  where  $K_{pcr}$  is rated extended primary current factor and  $I_{pr}$  is rated primary current. Factor  $K_{pcr}$  is in the case of conventional CTs usually just 1.2, but in the case of the KECA 80 Cxxx sensors the  $K_{pcr}$  factor is several times higher and equals 15.625 for KECA 80 C104 and 50 for KECA 80 C165.

Protection accuracies 5P400 and 5P630 (IEC 60044-8) or 5P1060-A2 (IEC61869-10) are guaranteed, for the advanced KECA 80 Cxxx sensors, from the current equal to  $K_{pcr} \times I_{pr}$  up to the current corresponding to  $K_{air} \times I_{pr}$  value, where  $K_{air}$  is, according to IEC 60044-8 and IEC 61869-10, the accuracy limit factor.

For this type of sensors the value of  $K_{pcr} \times I_{pr}$  is equal to the rated continuous thermal current  $I_{cth}$  (1 250 or 4 000 A) and the value of  $K_{air} \times I_{pr}$  is equal to the rated short-time thermal current  $I_{th}$  (31.5 and 50 kA according IEC 60044-8 and 85 kA according IEC 61869-10). The accuracy limits are described on the graph below.

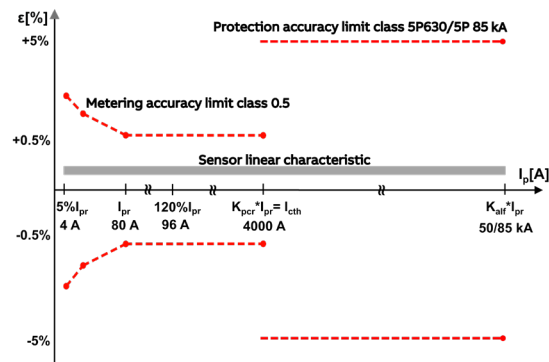

06

**Compactness**

Since the sensing elements are particularly small, and the same elements are used for both measurement and protection, the current sensors can be easily integrated into the switchgear. These facts enable the design of sensors in a very optimal way which contributes to high level of switchgear simplification.

**Rated parameters**

Because the sensors are highly linear within a very wide range of currents, the same single sensor can be used for the various rated currents associated with each specific application up to the specified maximum voltage for equipment. There is no need to specify other parameters such as burden, safety factor, etc. since they are standard

over the defined range. To achieve the correct function of the protection and control IED, the selected rated current, as well as the rated transformation ratio, must be properly set into the IED.

**Energy savings concept**

As there is no iron core, no necessity for high burden values and thus a possibility for low current losses and only one secondary winding needed, KECA 80 Cxxx sensors exhibit extremely low energy consumption that is just a fraction of that transferred to heat in conventional CTs. This fact contributes to huge energy savings during its entire operating life, supporting the world-wide effort to reduce energy consumption.

**Correction factors**

The amplitude and phase error of a current sensor is, in practice, constant and independent of the primary current. Due to this fact it is an inherent and constant property of each sensor and it is not considered as unpredictable and influenced error. Hence, it can be easily corrected in the IED by using appropriate correction factors, stated separately for every sensor.

Values of the correction factors for the amplitude and phase error of a current sensor are mentioned on the sensor label (for more information please refer to Instructions for installation, use and maintenance) and should be uploaded without any modification into the IED before the sensors are put into operation (please check available correction class in the IED manual). To achieve required accuracy classes it is recommended to use all correction factors (Cfs): amplitude correction factor (aI) and phase error correction factor (pI) of a current sensor.

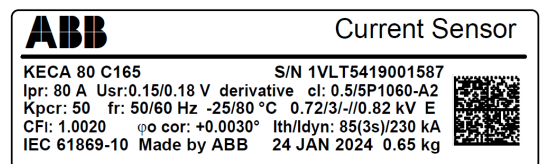

07

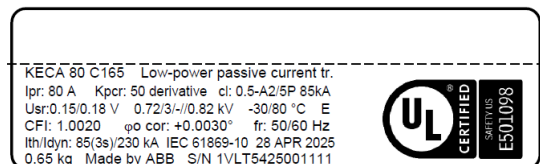
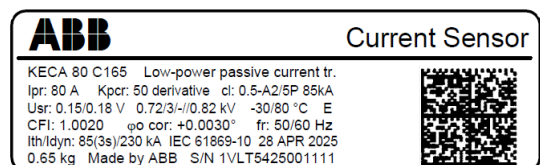

08

### Secondary cables

The sensor is equipped with a cable for connection with the IED. The cable connector is type RJ-45. The sensor accuracy classes are verified up to the RJ-45 connector, i.e. considering also its secondary cable. These cables are intended to be connected directly to the IED, and subsequently neither burden calculation nor secondary wiring is needed. Every sensor is therefore accuracy tested when equipped with its own cable and connector.

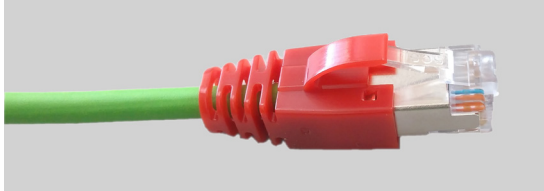

—  
09

### Connector adapters

To provide connectivity between a sensor with a RJ-45 cable connector and IEDs with Twin-BNC connectors a group of adapters were designed. To provide connectivity between current and voltage sensors with RJ-45 cable connectors and IEDs with RJ-45 connector the coupling adapter was designed. The use of connector or coupling adapters has no influence on the current and/or voltage signal and accuracy of the sensor with the cable. For more information about connector adapters and coupling adapter refer to Doc. No. 1VLC000710 - Sensor accessories.

### Certifications

KECA 80 C165 - UL certified (UL file number E501098)



### Standards

Current sensors: IEC 60044-8 (2002-07)

Instrument transformers –

Part 8: Electronic current transformers

IEC 61869-10 (2017-12) Instrument transformers

Part 10: Additional requirements for low-power passive current transformers

### Temperature category

- Operation -25°C/+80°C
- Operation for UL: -30°C/+80°C
- Transport and storage: -40°C/+80°C

### Cable

- Length: 5 m
- Connector: RJ-45 (CAT-6)

Current sensor parameters	Standard	KECA 80 C104	KECA 80 C165
<b>Highest voltage for equipment and test voltages</b>			
Highest voltage for equipment, $U_m$	IEC 60044-8 IEC 61869-10		0.72 kV
Power frequency voltage withstand test on primary terminals	IEC 60044-8 IEC 61869-10		3 kV
<b>Rated values</b>			
Rated primary current, $I_{pr}$	IEC 60044-8 IEC 61869-10		80 A
Rated transformation ratio, $K_{ra}/K_r$	IEC 60044-8 IEC 61869-10		150 mV at 50 Hz 180 mV at 60 Hz
Rated secondary output, $U_{sr}$	IEC 60044-8 IEC 61869-10		3 mV/Hz 150 mV at 50 Hz 180 mV at 60 Hz
Rated continuous thermal current, $I_{cth}$	IEC 60044-8	up to 1 250 A	up to 4 000 A
	IEC 61869-10	up to 4 000 A	up to 4 000 A
Rated short-time thermal current, $I_{th}$	IEC 60044-8	31.5 kA/3s	50 kA/3s
	IEC 61869-10	85 kA/3s	85 kA/3s
Rated dynamic current, $I_{dyn}$	IEC 60044-8	80 kA	125 kA
	IEC 61869-10	230 kA	230 kA
Rated frequency, $f_r$	IEC 60044-8		50/60 Hz
	IEC 61869-10		
Rated extended primary current factor, $K_{pcr}$	IEC 60044-8	15,625	50
	IEC 61869-10	50	50
Accuracy limit factor, $K_{alf}$	IEC 60044-8	400	630
	IEC 61869-10	1060	1060
Accuracy class	IEC 60044-8	0.5/5P400	0.5/5P630
	IEC 61869-10	0.5-A2/5P 85kA	0.5-A2/5P 85kA
Rated burden, $R_{br}$	IEC 60044-8		10 M $\Omega$
	IEC 61869-10		2 M $\Omega$ /50 pF

**Ordering data**

Type of sensor	Standard	for UniGear ZS1 12/17.5 kV	for other applications (e.g. OneFit)
KECA 80 C104	IEC 60044-8	1VL5400065V0101	1VL5400065V0102
	IEC 61869-10	1VL5400065V1101	1VL5400065V1102
KECA 80 C165	IEC 60044-8	1VL5400069V0101	1VL5400069V0102
	IEC 61869-10	1VL5400069V1101	1VL5400069V1102
KECA 80 C165 + UL certification	IEC 61869-10	1VL5400069V1201	1VL5400069V1202

**Dimensional Drawing**

KECA 80 C104

Outline drawing number: 2RKA015625A0001

Weight: 0.4 kg

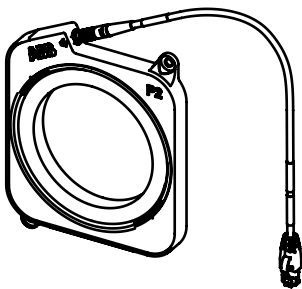
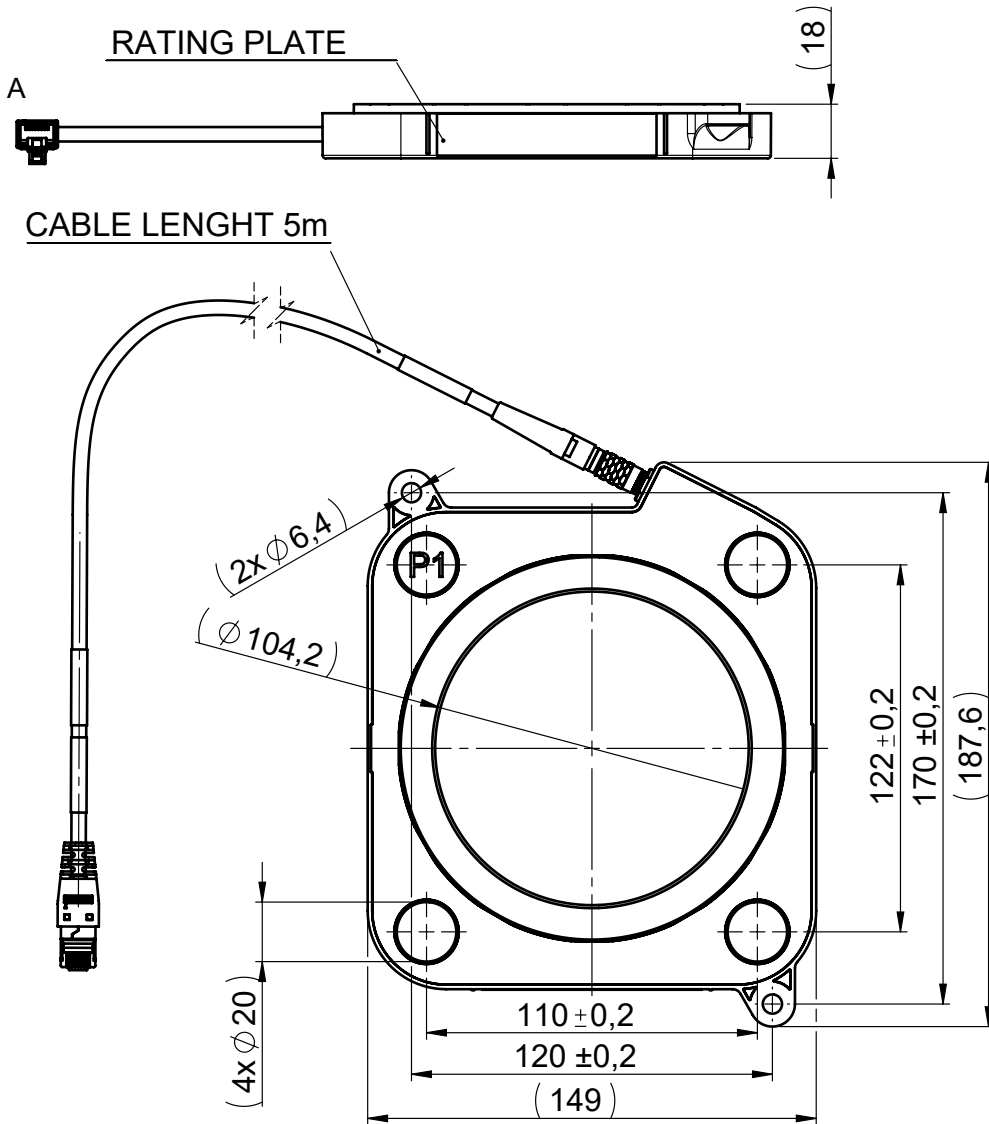

CONNECTOR RJ45 CAT6

IEC 60044-8

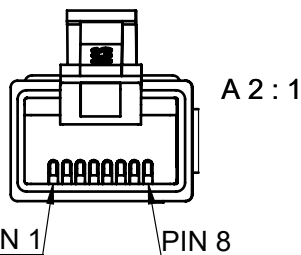

PIN 4 - COIL START (S1)  
PIN 5 - COIL END (S2)

CONNECTOR RJ45 CAT6

IEC 61869-10

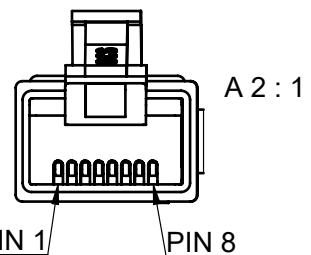

PIN 1 - COIL START (S1)  
PIN 2 - COIL END (S2)

**Dimensional Drawing**

KECA 80 C165

Outline drawing number: 2RKA015626A0001

Weight: 0.65 kg

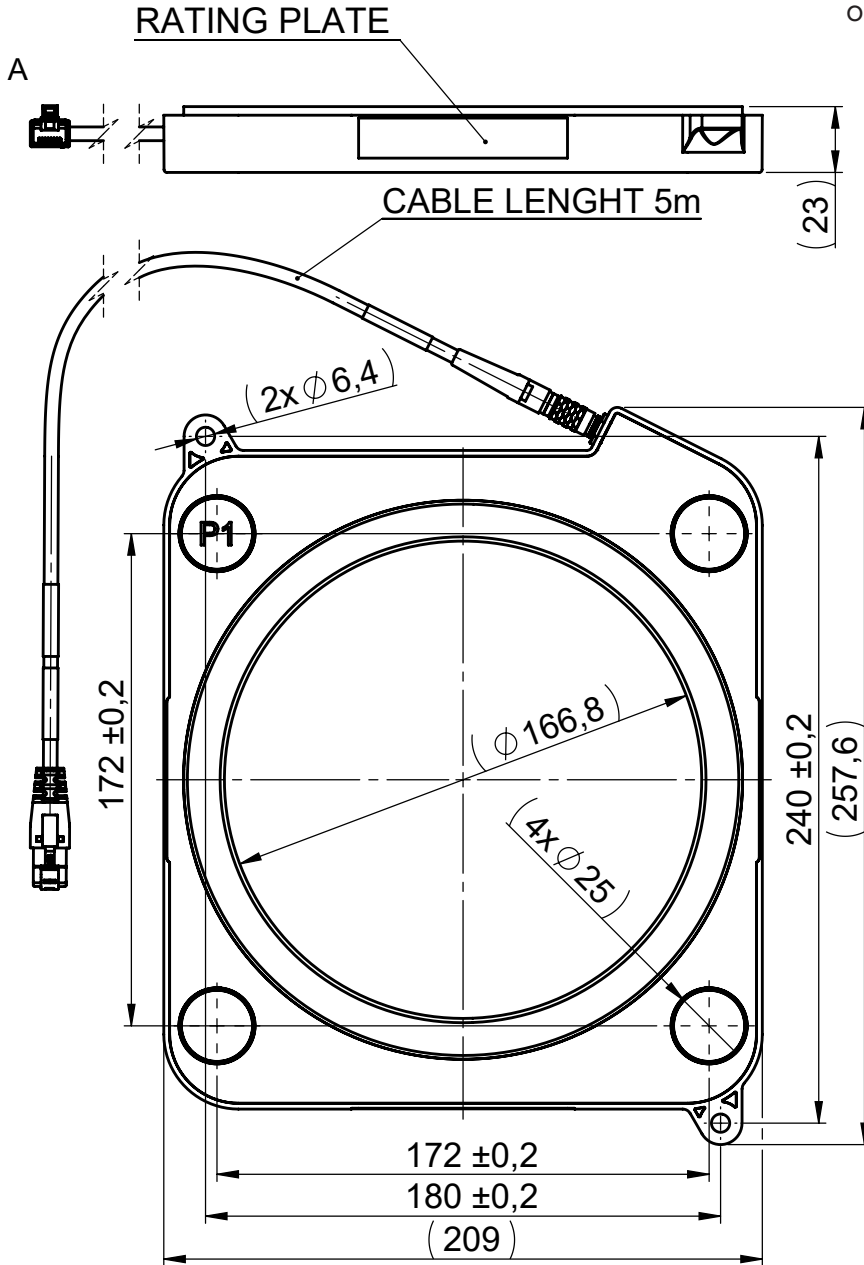

CONNECTOR RJ45 CAT6  
IEC 60044-8

A 2 : 1

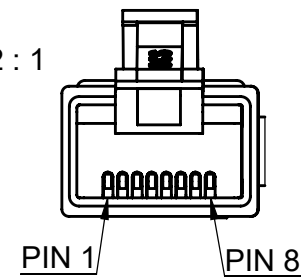

PIN 4 - COIL START (S1)  
PIN 5 - COIL END (S2)

CONNECTOR RJ45 CAT6  
IEC 61869-10

A 2 : 1

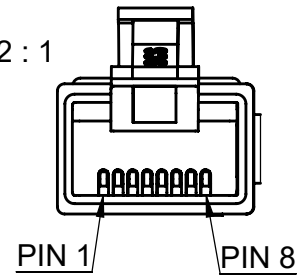

PIN 1 - COIL START (S1)  
PIN 2 - COIL END (S2)

3D VIEW

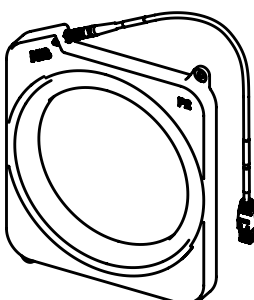

---

CONTACT US

**ABB s.r.o.**

ELDS Brno

Videnska 117, 619 00 Brno,  
Czech Republic

Tel.: +420 547 152 021

+420 547 152 854

E-mail: kontakt@cz.abb.com

**[www.abb.com](http://www.abb.com)**

---

NOTE

We reserve the right to make technical changes or modify the contents of this document without prior notice. With regard to purchase orders, the agreed particulars shall prevail. ABB does not accept any responsibility whatsoever for potential errors or possible lack of information in this document.

We reserve all rights in this document and in the subject matter and illustrations contained therein. Any reproduction, disclosure to third parties or utilization of its contents - in whole or in parts - is forbidden without prior written consent of ABB.

Copyright© 2026 ABB  
All rights reserved